

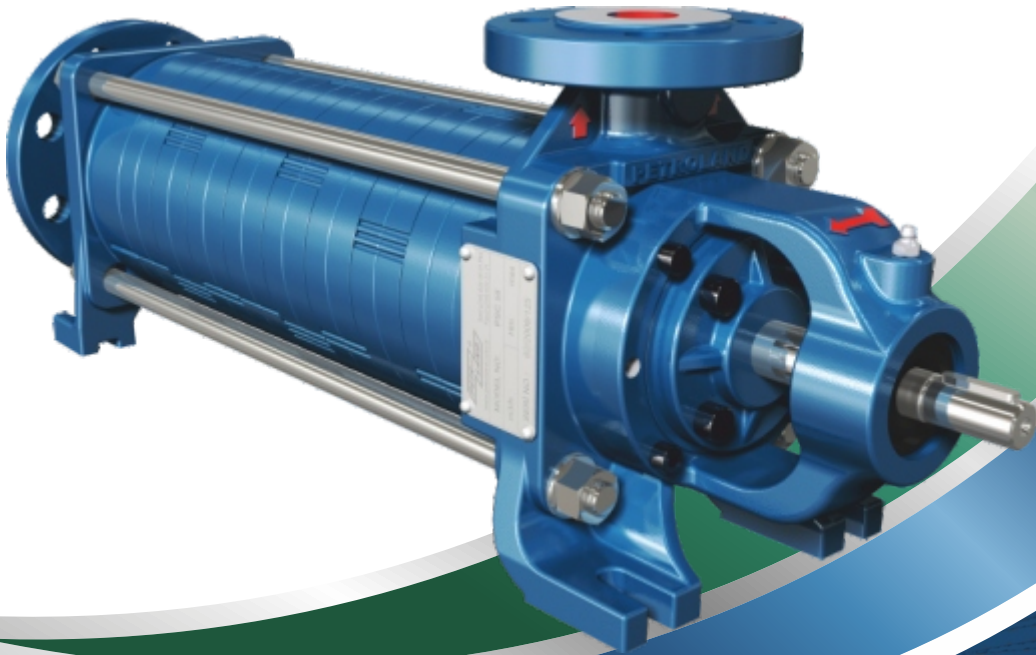

PS Series Multistage Side Channel Pumps



ATEX
94 / 9 / AT

www.petroland.com.tr

Petroland San. ve Tic. Ltd. ti.

Alemda Cad. Güven San. Sitesi R Blok No: 7-8 Ümraniye - İstanbul / TURKEY

Tel: +90 216 634 45 00 Faks: +90 216 634 21 21 / info@petroland.com.tr



LPG Industry



Oil Industry



Pharmaceutical Industry



Ship Yards



Petrochemical Industry



Chemical Industry

The solution for critical conditions

Petroland PS pump is a self-priming side channel pump capable of handling gas along with the medium and operates at a low noise level. PS pumps are used for problem-free pumping of clean liquids at unfavourable suction side conditions. They are also very suitable for positive suction heads below 0,5m. PS pumps provide the most appropriate solutions for liquefied gases, liquids under vapour pressure, refrigerants and especially PS applications.

Side channel designs fill the hydraulic performance void between positive displacement pumps and centrifugal pumps. Fully open "star" impellers interact with the side channel casing creating an intense transfer of energy to the pumped liquid or liquid / gas mixture. The corresponding pressure increase (pump head) equals 5 to 10 times the amount generated by a similar size centrifugal pump at the same RPM.

Features :

- Self-priming
- High pressure at low capacity
- Liquefied gas handling
- High resistant materials
- Performance curve characteristic
- High efficiency
- Low NPSH value
- Modular hydraulic system
- Ability to pump vapour laden liquides (up to 50%)

Technical Data :

Capacity: 0.5 - 35 m³/h
Head: max. 35 bar
Casing pressure: max. 40 bar
Speed: max. 1750 d/d (60 Hz)
Working temperature: max. 220C
Flange connections: DIN2501 - ANSI 150 & 300 / PN40

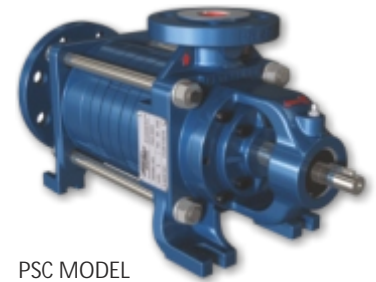

PSC MODEL



PSD MODEL

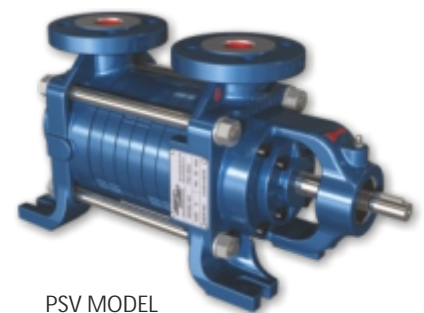

PSV MODEL

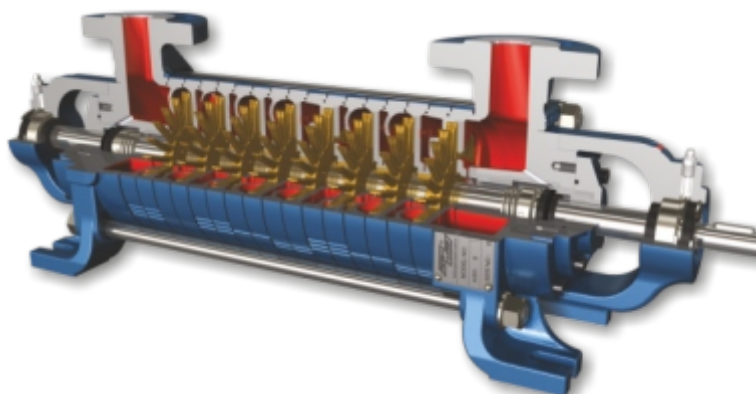

The design of the side channel pump allows for the transfer of liquid-gas mixture with up to 50% vapor; therefore eliminating possible air or vapor locking that can occur in other pump designs. A special suction impeller lowers the NPSH requirement for the pump.

The side-channel pump design is similar to a regenerative turbine in that the impeller makes regenerative passes through the liquid. However, the actual design of the impeller and casing as well as the principles of operation differ greatly. The side-channel pump has a channel only in the discharge stage casing (A) and a flat surface which is flush with the impeller on the suction stage casing (B). A star-shaped impeller (C) is keyed to the shaft and is axially balanced through equalization holes (D) in the hub of the impeller.

The liquid or liquid/vapor mixture enters each stage of the pump through the inlet port (E). Once the pump is initially filled with liquid, the pump will provide a siphoning effect at the inlet port. The effect is similar to what happens in water ring pumps. The water remaining in the pump casing forms a type of water ring with a free surface. A venturi effect is created by the rotation of the impeller and the free surface of the water, thus pulling the liquid into the casing.

After the liquid is pulled through the inlet port, it is forced to the outer periphery of the impeller blade by centrifugal action. It is through this centrifugal action that the liquid is accelerated and forced into the side channel. The liquid then flows along the semicircular contour of the side channel from the outermost point to the innermost point until once again it is accelerated by the impeller blade.

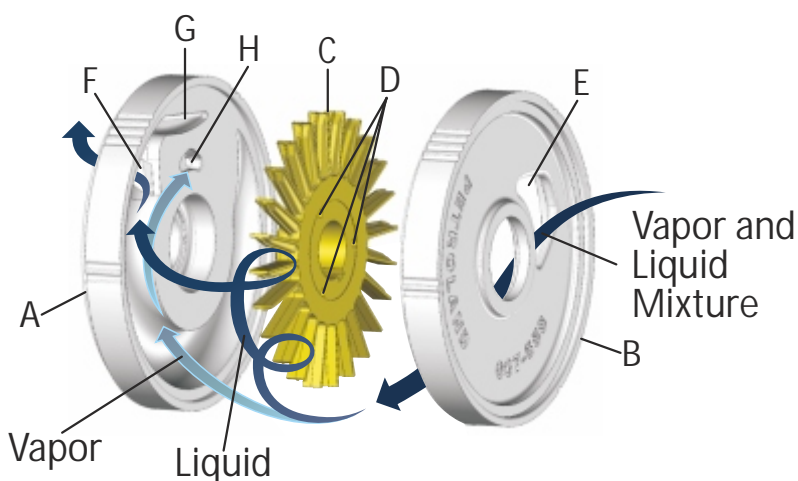

Item	Description
A	Discharge Casing
B	Suction Casing
C	Vane Wheel Impeller
D	Equalization Holes
E	Liquid Inlet
F	Liquid Outlet
G	Mini Channel
H	Vapor Balance Outlet

Principle of Side Channel Operation



PS Series

SERIES	1000	2000	3000	4000	5000	6000
Number of Stages	1 - 2 - 3 - 4 - 5 - 6 - 7 - 8					
Inlet Flange	1½ (DN40)	2½ (DN65)	2½ (DN65)	3 (DN80)	4 (DN100)	4 (DN100)
Outlet Flange	¾ (DN20)	1¼ (DN32)	1¼ (DN32)	1½ (DN40)	2 (DN50)	2½ (DN65)
Inlet - Outlet Flanges for PSD & PSV	¾ (DN20)	1¼ (DN32)	1¼ (DN32)	1½ (DN40)	2 (DN50)	2½ (DN65)
Speed (50 Hz) / Speed (60Hz)	1450 / 1750					
Maximum Working Pressure, Bar	35 Bar (510)					
Differential Range Head ft [m]	50 (15)–690 (210)	65 (20)–1050 (320)	30 (10)–820 (250)	30 (10)–805 (245)	30 (10)–950 (290)	30 (10)–1150 (350)
Minimum Temperature °C (°F)	-40° (-40°)					
Maximum Temperature °C (°F)	220° (430°)					
NPSH ft (m)	1.6 (.5) – 13 (4)	2 (.6) – 3.3 (1)	1.6 (.5) – 6.6 (2)	1.3 (.4) – 8.2 (2.5)	1.3 (.4) – 12 (3.5)	4.6 (1.4) – 8.2 (2.5)
Maximum Viscosity cSt (SSU)	230 (1050)					
Maximum Proportion of Gas Allowable	50 %					
Connection Norms	ANSI 150 & 300 Flange / DIN EN 1092 & DIN 2501 PN40 Flange					
Casing Material Options	GG25 (Cast Iron) / GGG50 (Ductile Iron) / GSC25N (Steel) / AISI 316 (Stainless Steel)					
Impeller Material Options	Alloyed Bronze / Bronze RG7 / AISI 316 Stainless Steel					
Shaft Sealing Options	Mechanical seal / Cartridge Mechanical seal / Cartridge double Mechanical seal / Packing gland					
Mechanical Seal Material Options	SIC-Car-Viton / SIC-SIC-Kalrez / SIC-SIC-Teflon					
Pump rpm	1450 rpm (1750 rpm / 60Hz)					
Capacity	Max: 35 m³/h (42 m³/h / 60Hz)					
Accessories	Likquid Sensor (Liquid Level Switch) / Collector / Reducer / Exproof Coupling / By-Pass Valve					

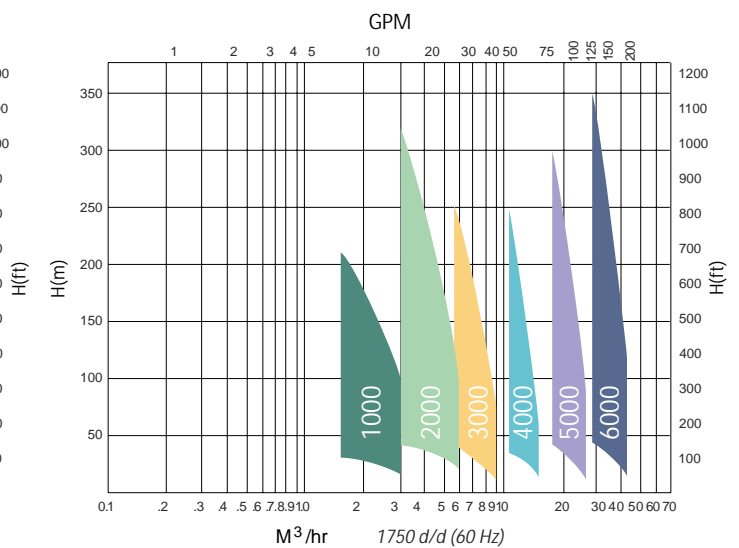
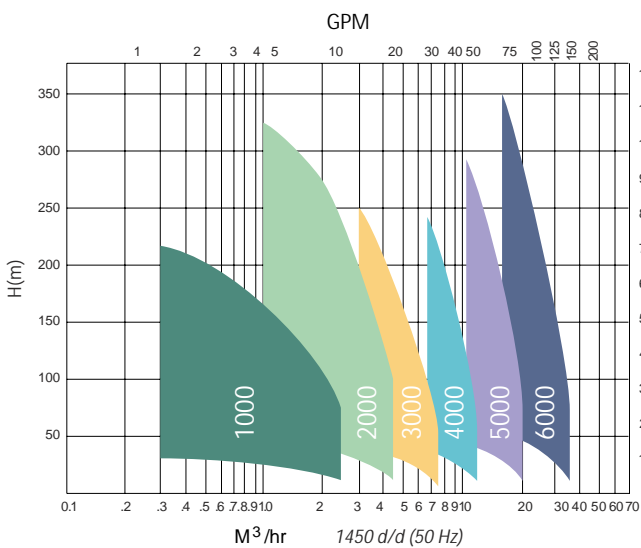

Performance Curves

P S C 300 8-2 B 1 LS

Accessories
 LS : With Liquid Sensor

Shaft Sealing:
 1 : Mechanical Seal - Single
 2 : Mechanical Seal - Double
 3 : Cartridge Mechanical Seal - Double
 4 : Packing Gland

Impeller Materials
 A : Brass
 B : Bronze
 P : 316 Stainless Steel

Casing Material
 1 : GG25 (Cast Iron)
 2 : GGG40.3 (Ductile Iron)
 3 : GSC25N (Steel)
 4 : AISI 316 Stainless Steel

Stages
 1 - 2 - 3 - 4 - 5 - 6 - 7 - 8

Pump Size
 100 - 200 - 300 - 400 - 500 - 600

Case Design
 C : Inlet Horizontal, Outlet Vertical
 D : Inlet - Outlet Vertical (Double Ball Bearing)
 V : Inlet - Outlet Vertical (Single Ball Bearing)

S: Side Channel Pump

P: Petroland

Side Channel Pumps - type PSC

Pumps of the series PSC are horizontal and self-priming, side channel pumps with a NPSH inducer stage suitable for handling liquids which do not contain solid or abrasive matter. The NPSH inducer stage allows the pump to operate on the suction side under unfavourable conditions and at positive suction heads lower than 0.5 m.

The range comprises of six sizes each with 1 to 8 hydraulic stages whereby an optimum rating is obtained, ensuring the pump selected meets the required capacity and head.

The different material possibilities with uniform dimensions and performance characteristics as well as the standard exchangeable components, coupling with mechanical seal, packing gland and cartridge seal make the PSC particularly recommendable.

The pumps of the PSC /LS series have a retaining stage to avoid the dry running by controlling the liquid level in the pump. This design is especially developed for the handling of liquids under vapour pressure or when pumping from underground tanks.

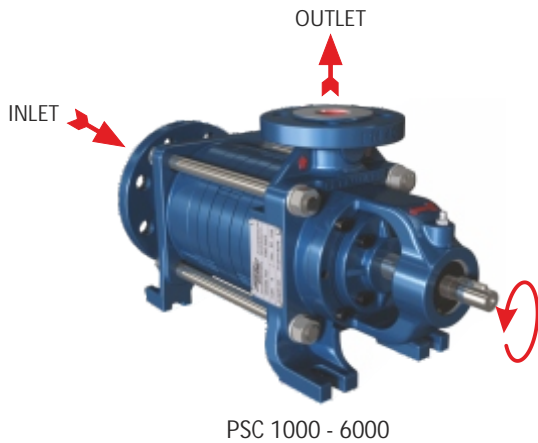

Model: PSC (With Cartridge Mechanical Seal)



Model: PSC (With Mechanical Seal)



Model: PSC (With Packing Gland)



Model: PSC (With Liquid Sensor)

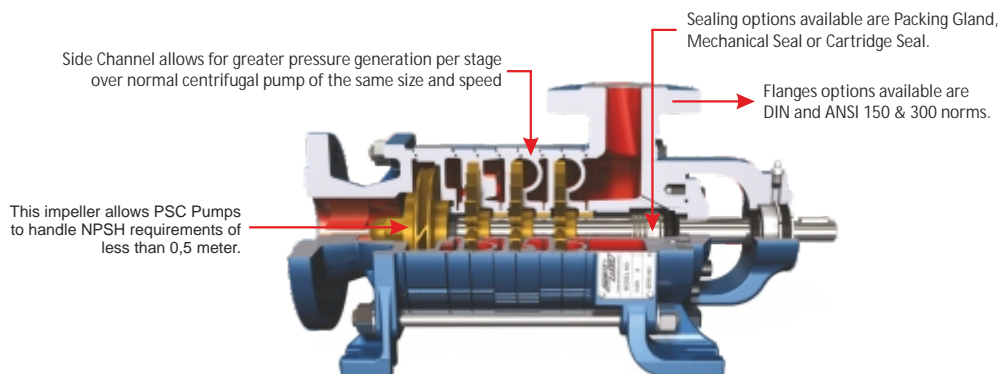

PSC Model

Dimensional Drawing of Bare Shaft Pump

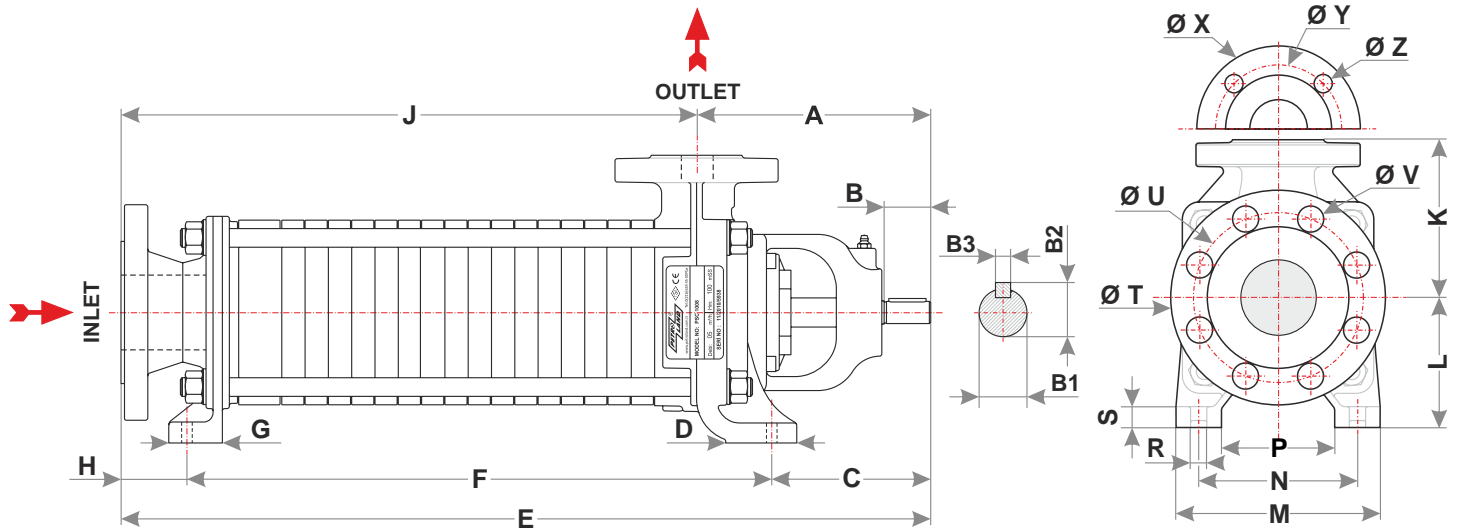

Pump Size	Pump Inlet	Pump Outlet	Dimensions [mm]																					
			A	B	C	D	G	H	K	L	M	N	P	R	S	T	U	V	X	Y	Z	B1	B2	B3
1000	40	20	170	25	114	45	45	45	100	100	142	105	60	12	14	150	110	18x4	105	75	14x4	16	18.2	5
2000	65	32	200	40	134	60	50	53	135	112	180	135	110	14	16	185	145	18x8	140	100	18x4	19	21.5	6
3000	65	32	200	40	134	60	50	53	135	112	180	135	110	14	16	185	145	18x8	140	100	18x4	19	21.5	6
4000	80	40	195	45	140	65	55	63	140	132	200	155	120	14	16	200	160	18x8	150	110	18x4	24	27.0	8
5000	100	50	237	50	160	65	60	68	165	160	220	170	120	16	18	235	190	22x8	165	125	18x4	28	31.0	8
6000	100	65	262	65	172	70	60	70	180	180	255	195	145	16	18	235	190	22x8	185	145	18x8	32	35.5	10

Dimensions and Weights According to Stage Numbers																																
Pump Size	Number of Stage																															
	1				2				3				4				5				6				7				8			
	E	F	J	Kg	E	F	J	Kg	E	F	J	Kg	E	F	J	Kg	E	F	J	Kg	E	F	J	Kg	E	F	J	Kg				
1000	365	206	195	20	399	240	229	22	433	274	263	24	467	308	297	26	501	342	331	28	535	376	365	30	569	410	399	32	603	444	433	34
2000	415	228	213	33	455	268	253	36	495	308	293	39	535	348	333	42	575	388	373	45	615	428	413	48	655	468	453	51	695	508	493	54
3000	415	228	213	33	455	268	253	36	495	308	293	39	535	348	333	42	575	388	373	45	615	428	413	48	655	468	453	51	695	508	493	54
4000	463	260	268	46	518	315	323	53	573	370	378	60	628	425	433	67	683	480	488	74	738	535	543	81	793	590	598	88	848	645	653	95
5000	542	315	305	69	617	390	380	80	692	465	455	91	767	540	530	102	842	615	605	113	917	690	680	124	992	765	755	135	1067	840	830	146
6000	600	358	338	99	688	441	426	115	776	529	514	131	864	617	602	147	952	705	690	163	1040	793	778	179	1128	881	866	195	1216	969	954	211

Flange dimensions in accordance with PN40 DIN 2545 at standard pumps. (upon request ANSI 150&300 norm)

PSC Model

Spare Part List of Pump with Mechanical Seal

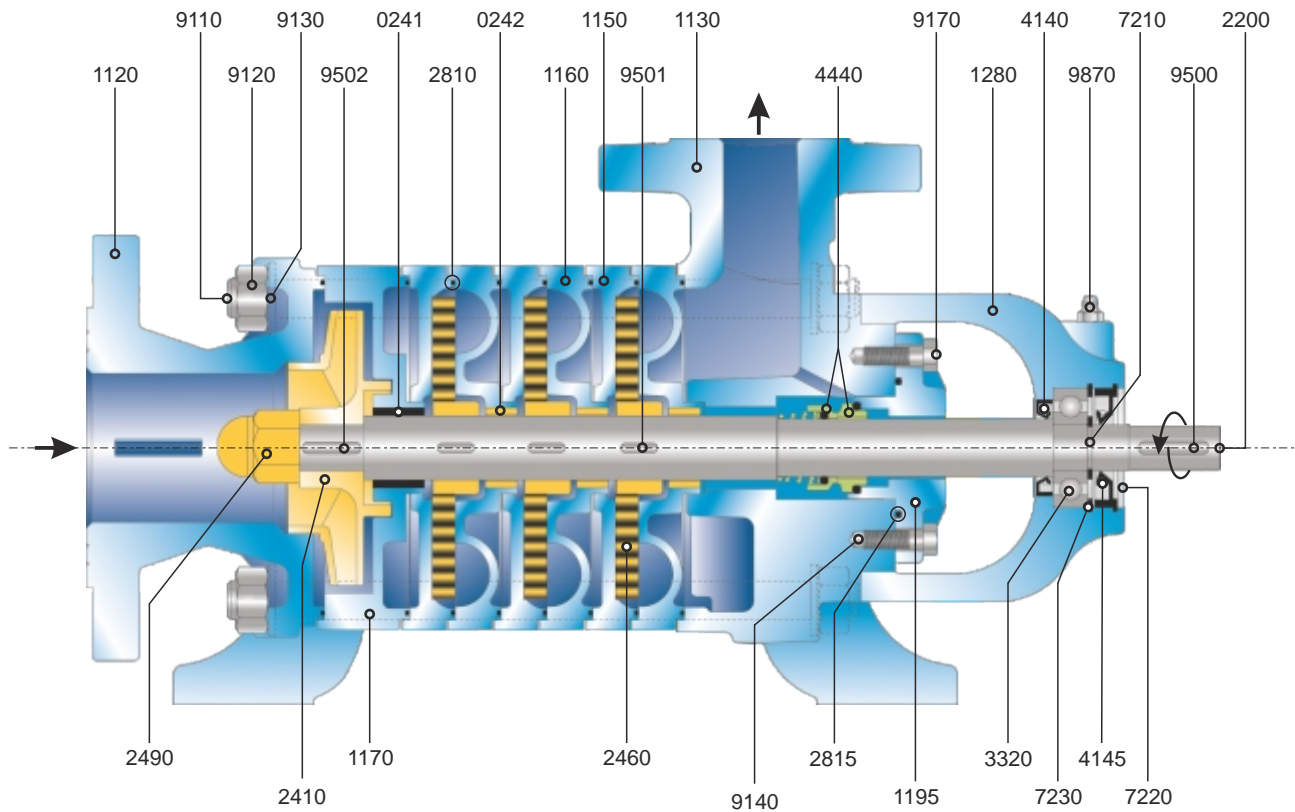

Item	Part List	Item	Part List	Item	Part List
0241	Impeller Bushing	2460	Vane Impeller	9110	Tie Bolt
0242	Vane Impeller Bushing	2490	Hexagonal Shaft Nut (<i>Left-Hand Thread</i>)	9120	Tie Bolt Nut
1120	Suction Casing	2810	Stage O-Ring	9130	Tie Bolt Washer
1130	Discharge Casing	2815	Mechanical Seal Casing O-Ring	9140	Screw for Bearing Casing
1150	Suction Body	3320	Ball Bearing	9170	Screw for Mechanical Seal Casing
1160	Discharge Body	4140	Lip Seal (Inner)	9500	Flat Key for Coupling
1170	Impeller Body	4145	Lip Seal (Outer)	9501	Flat Key for Vane Impeller
1195	Mechanical Seal Casing	4440	Mechanical Seal	9502	Flat Key for Impeller
1280	Bearing Casing	7210	Snap Ring for Shaft	9870	Grease Fitting
2200	Shaft	7220	Snap Ring for Bearing		
2410	Impeller	7230	Snap Ring for Lip Seal		

PSC 1001-1008 Sizes Performance Curves

PSC 2001-2008 Sizes Performance Curves

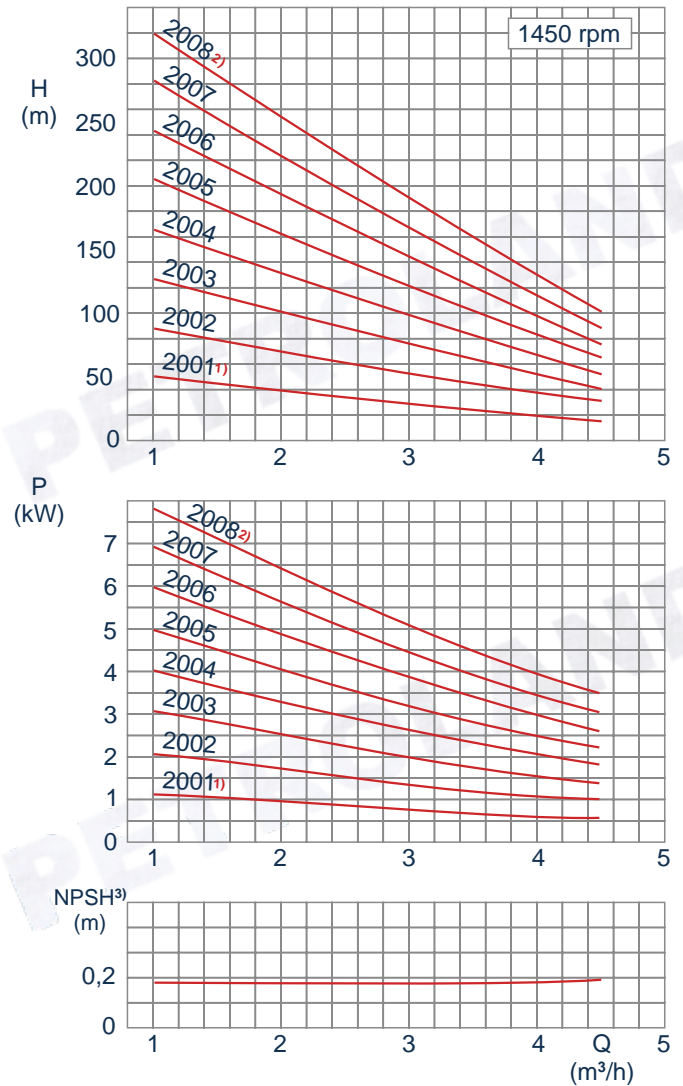
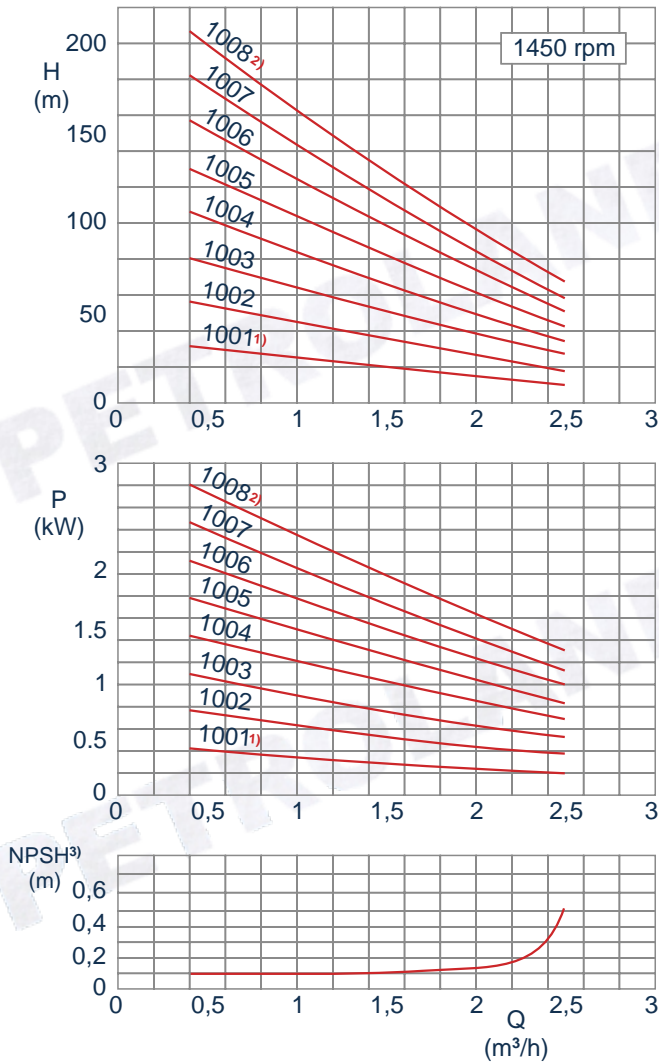

- 1) 1 Stage pump can not be ordered with liquid sensor.
- 2) 8 Stage pump with liquid sensor is produced upon request

General: Values are valid for water $\rho = 1 \text{ kg/dm}^3$ and $\nu = 1 \text{ cSt}$.

Design tolerances: Capacity $\pm 5\%$ - Delivery head $\pm 5\%$ - Power $+ 10\%$
The tolerance for the delivery head is extended by 5% each.

PSC 3001-3008 Sizes Performance Curves

PSC 4001-4008 Sizes Performance Curves

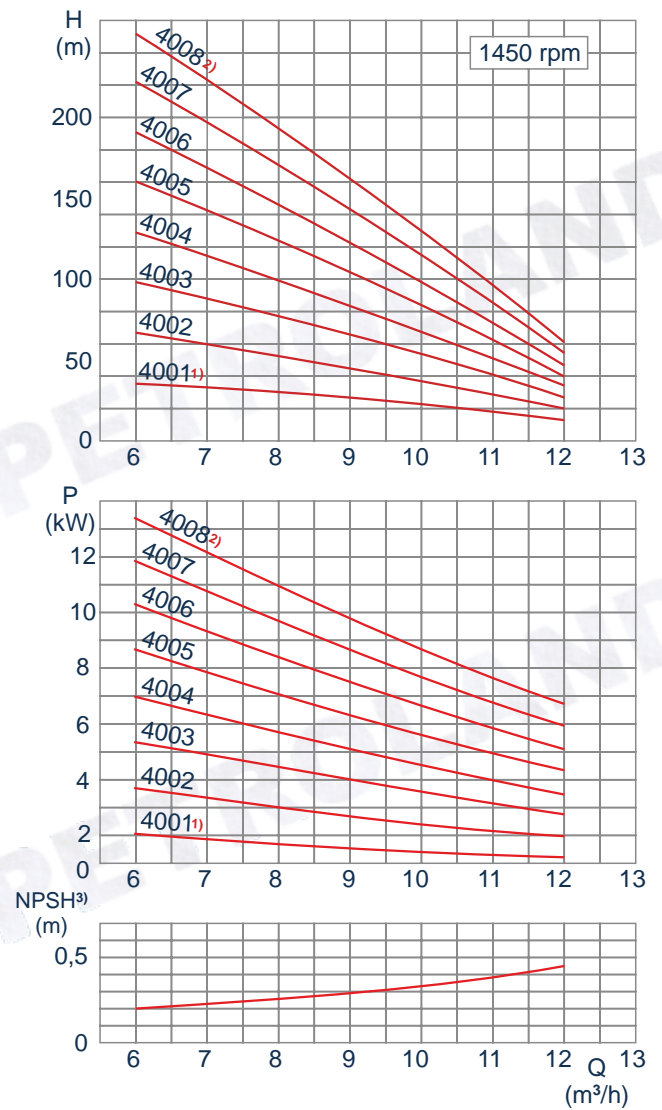
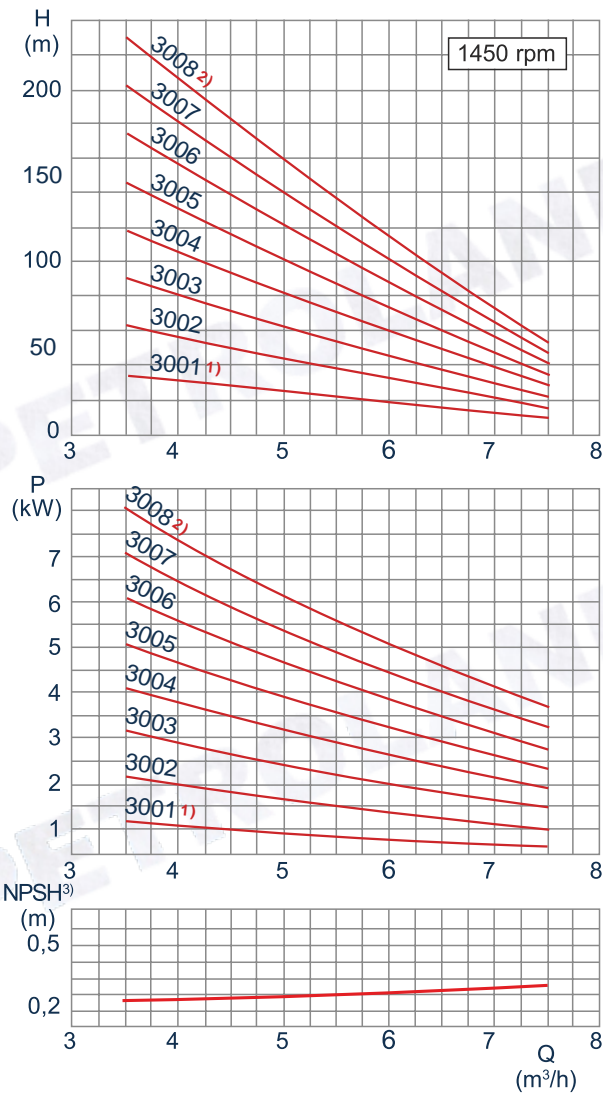

- 1) 1 Stage pump can not be ordered with liquid sensor.
- 2) 8 Stage pump with liquid sensor is produced upon request

General: Values are valid for water $\rho = 1 \text{ kg/dm}^3$ and $\nu = 1 \text{ cSt}$.

Design tolerances: Capacity $\pm 5\%$ - Delivery head $\pm 5\%$ - Power $+ 10\%$
The tolerance for the delivery head is extended by 5% each.

PSC 5001-5008 Sizes Performance Curves

PSC 6001-6008 Sizes Performance Curves

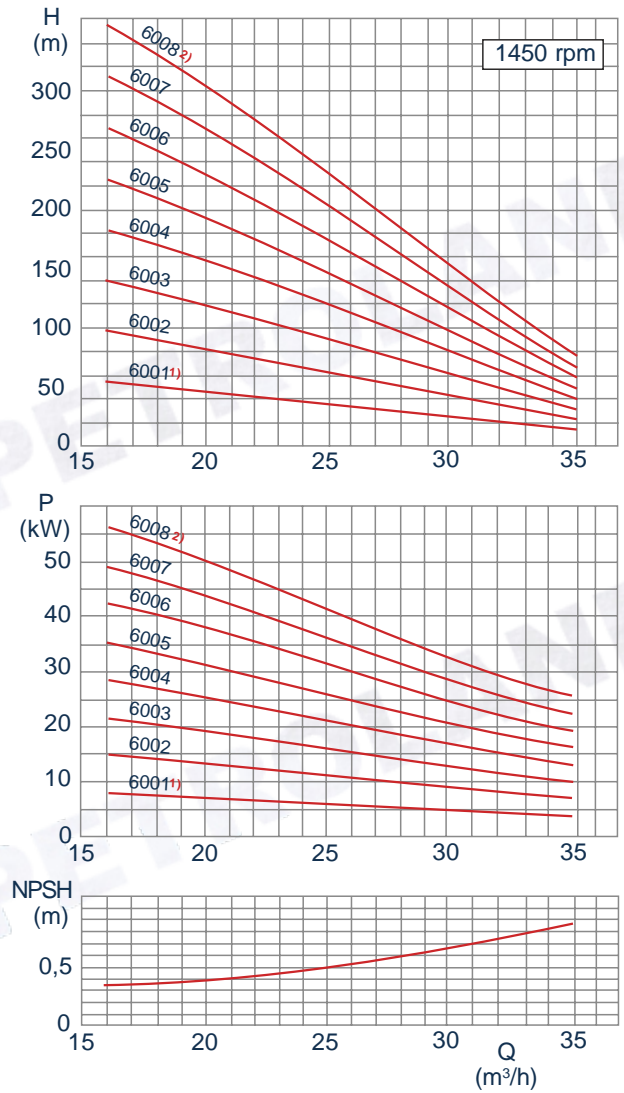
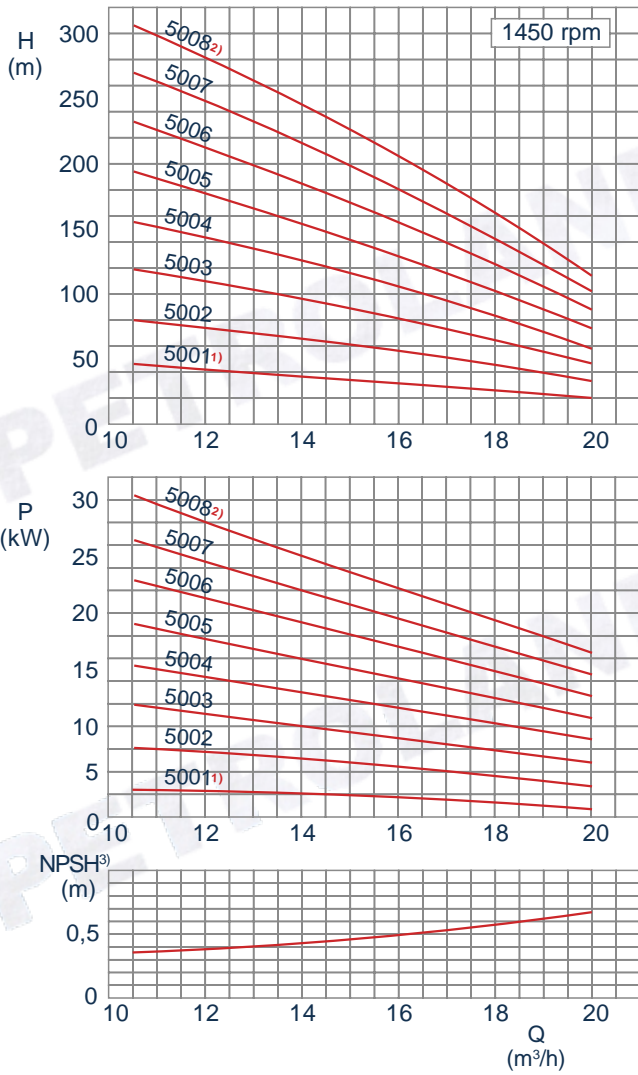

- 1) 1 Stage pump can not be ordered with liquid sensor.
- 2) 8 Stage pump with liquid sensor is produced upon request

General: Values are valid for water $\rho = 1 \text{ kg/dm}^3$ and $\nu = 1 \text{ cSt}$.

Design tolerances: Capacity $\pm 5\%$ - Delivery head $\pm 5\%$ - Power $+ 10\%$
The tolerance for the delivery head is extended by 5% each.



Model: PSD (With Mechanical Seal)



Model: PSD (With Packing Gland)

Side Channel Pumps - type PSD

Pumps of the series PSD are horizontal and self-priming, side channel pumps of segmental type construction which are able to handle entrained gases.

These pumps have been specifically designed for heavy duty applications within industry. When pumping pure, turbid or aggressive media the design is ideally suited.

The range comprises of six sizes each with 1 to 8 hydraulic stages where by an optimum rating is obtained, ensuring the pump selected meets the required capacity and head. PSD is a Side Channel pump operates at a low noise level.

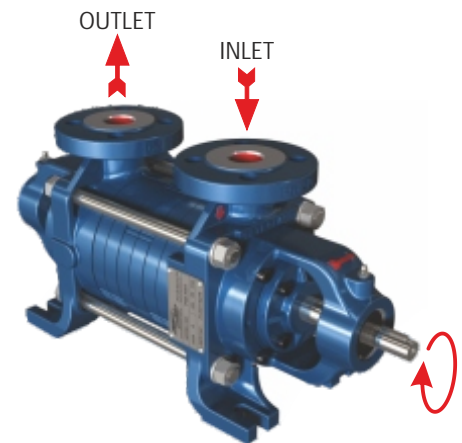

PSD 1000 - 6000

Side Channel allows for greater pressure generation per stage over normal centrifugal pump of the same size and speed

Sealing options available are Packing Gland, Mechanical Seal or Cartridge Seal.

Flanges options available are DIN and ANSI 150 & 300 norms.

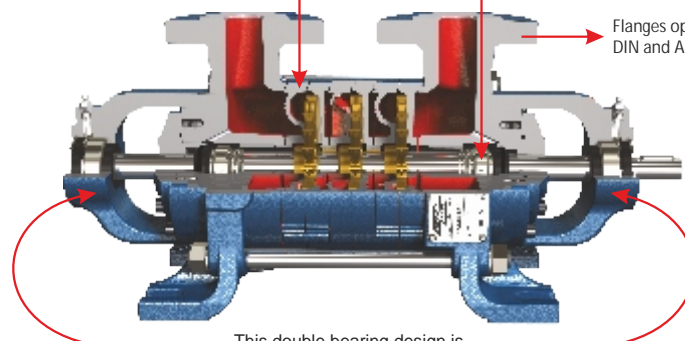

This double bearing design is produced for heavy duty applications

PSD Model

Dimensional Drawing of Bare Shaft Pump

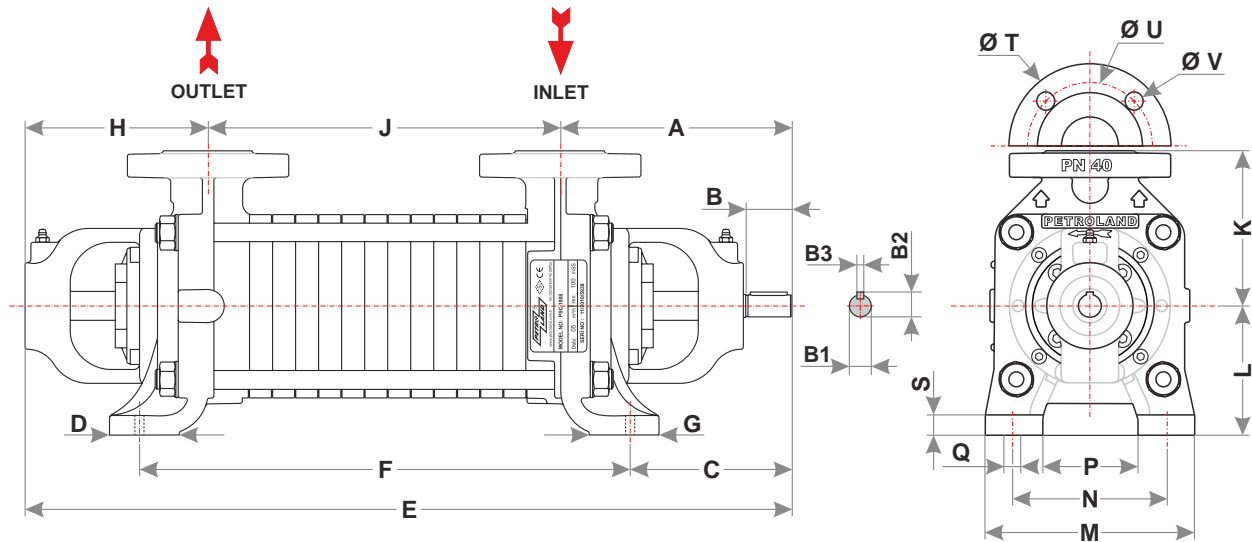

Pump Size	Pump Inlet	Pump Outlet	Dimensions [mm]																		
			A	B	C	D	G	H	K	L	M	N	P	Q	S	T	U	V	B1	B2	B3
1000	20	20	170	25	112	45	45	140	100	100	142	105	60	12	14	105	75	14x4	16	18.2	5
2000	32	32	200	40	134	65	65	160	132	112	180	135	110	14	16	140	140	18x4	19	21.5	6
3000	32	32	200	40	134	65	65	160	132	112	180	135	110	14	16	140	140	18x4	19	21.5	6
4000	40	40	195	45	140	70	70	147	140	132	200	155	120	14	16	150	150	18x4	24	27.0	8
5000	50	50	237	50	160	70	70	182	165	160	220	170	120	16	18	165	165	18x4	28	31.0	8
6000	65	65	262	65	172	70	70	197	180	180	260	195	145	16	18	185	185	18x8	32	35.5	10

Dimensions and Weights According to Stage Numbers																																
Pump Size	Number of Stage																															
	1				2				3				4				5				6				7				8			
	E	F	J	Kg	E	F	J	Kg	E	F	J	Kg	E	F	J	Kg	E	F	J	Kg	E	F	J	Kg	E	F	J	Kg				
1000	432	232	122	23	432	232	122	23	466	266	156	25	500	300	190	27	534	334	224	29	568	368	258	31	602	402	292	33	636	436	326	35
2000	506	280	146	41	506	280	146	42	546	320	186	45	586	360	226	48	626	400	266	51	666	440	306	54	706	480	346	57	746	520	386	60
3000	506	280	146	41	506	280	146	42	546	320	186	45	586	360	226	48	626	400	266	51	666	440	306	54	706	480	346	57	746	520	386	60
4000	500	270	159	47	555	325	214	54	610	380	269	61	665	435	324	68	720	490	379	75	775	600	434	82	830	655	489	89	885	710	544	96
5000	594	330	175	73	669	405	250	84	744	480	325	95	819	555	400	106	894	630	475	117	969	705	550	128	1044	780	625	139	1119	855	700	150
6000	669	384	210	103	757	472	298	119	845	560	386	135	933	648	474	151	1021	736	562	167	1109	824	650	183	1197	912	738	199	1285	1000	826	215

Flange dimensions in accordance with PN40 DIN 2545 at standard pumps. (upon request ANSI 150&300 norm)

PSD Model

Spare Part List of Pump with Mechanical Seal

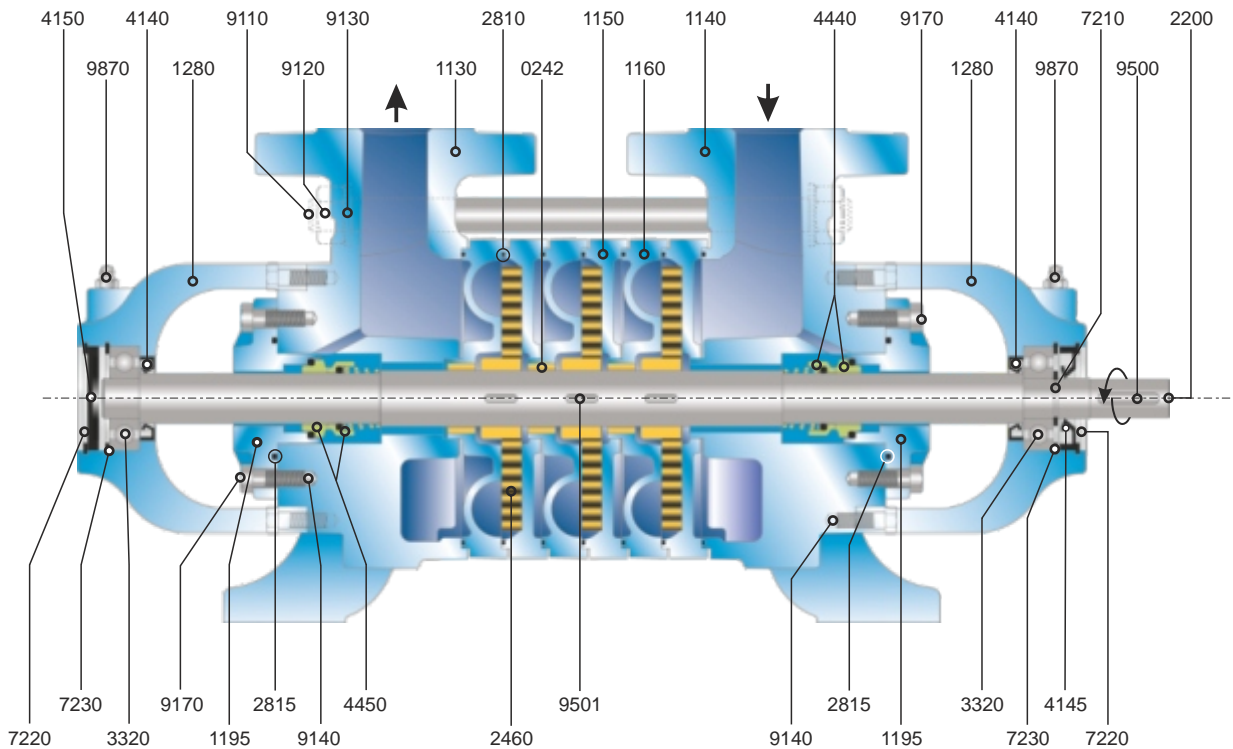

Item	Part List	Item	Part List	Item	Part List
0242	Vane Impeller Bushing	2815	Mechanical Seal Casing O-Ring	9110	Tie Bolt
1130	Discharge Casing	3320	Ball Bearing	9120	Tie Bolt Nut
1140	Suction Casing	4140	Lip Seal (Inner)	9130	Tie Bolt Washer
1150	Suction Body	4145	Lip Seal (Outer)	9140	Screw for Bearing Casing
1160	Discharge Body	4150	Dust Seal	9170	Screw for Mechanical Seal Casing
1195	Mechanical Seal Casing	4440	Mechanical Seal (Turn Right)	9500	Flat Key for Coupling
1280	Bearing Casing	4450	Mechanical Seal (Turn Left)	9501	Flat Key for Vane Impeller
2200	Shaft	7210	Snap Ring for Shaft	9870	Grease Fitting
2460	Vane Impeller	7220	Snap Ring for Bearing		
2810	Stage O-Ring	7230	Snap Ring for Lip Seal		



Model: PSV (With Mechanical Seal)



Model: PSV (With Packing Gland)

Side Channel Pumps - type PSV

Pumps of the series PSV are horizontal and self-priming, side channel pumps of segmental type construction which are able to handle entrained gases.

These pumps have been specifically designed for medium duty applications within industry. When pumping pure, turbid or aggressive media the design is ideally suited.

The range comprises of six sizes each with 1 to 8 hydraulic stages whereby an optimum rating is obtained, ensuring the pump selected meets the required capacity and head.

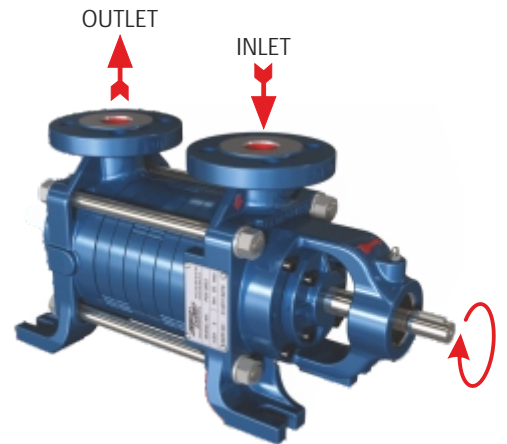

PSV 1000 - 6000

Side Channel allows for greater pressure generation per stage over normal centrifugal pump of the same size and speed

Sealing options available are Packing Gland, Mechanical Seal or Cartridge Seal.

Flanges options available are DIN and ANSI 150 & 300 norms.

Carbon Graphite Bushing

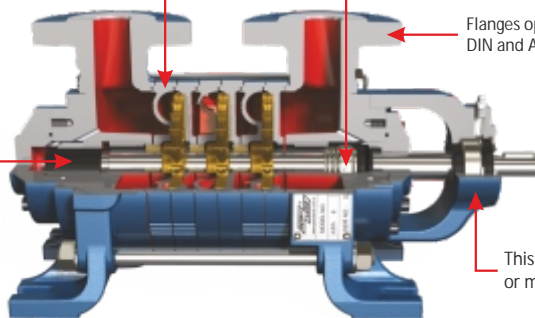

This single bearing design is produced for medium duty applications

PSV Model

Dimensional Drawing of Bare Shaft Pump

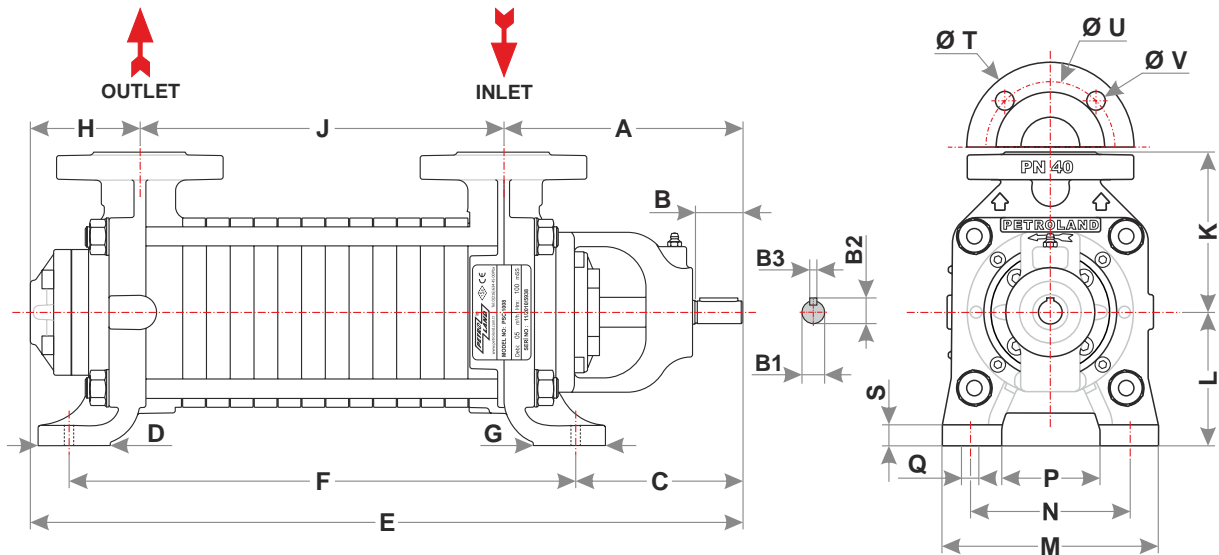

Pump Size	Pump Inlet	Pump Outlet	Dimensions [mm]																		
			A	B	C	D	G	H	K	L	M	N	P	Q	S	T	U	V	B1	B2	B3
1000	20	20	170	25	112	45	45	70	100	100	142	105	60	12	14	105	75	14x4	16	18.2	5
2000	32	32	200	40	134	65	65	95	132	112	180	135	110	14	16	140	140	18x4	19	21.5	6
3000	32	32	200	40	134	65	65	95	132	112	180	135	110	14	16	140	140	18x4	19	21.5	6
4000	40	40	195	45	140	70	70	70	140	132	200	155	120	14	16	150	150	18x4	24	27.0	8
5000	50	50	237	50	160	70	70	100	165	160	220	170	120	16	18	165	165	18x4	28	31.0	8
6000	65	65	262	65	172	70	70	100	180	180	260	195	145	16	18	185	185	18x8	32	35.5	10

Dimensions and Weights According to Stage Numbers																																
Pump Size	Number of Stage																															
	1		2		3		4		5		6		7		8																	
	E	F	J	Kg	E	F	J	Kg	E	F	J	Kg	E	F	J	Kg	E	F	J	Kg	E	F	J	Kg	E	F	J	Kg				
1000	362	232	122	23	362	232	122	23	396	266	156	25	430	300	190	27	464	334	224	29	498	368	258	31	532	402	292	33	566	326	326	35
2000	440	280	146	41	440	280	146	42	480	320	186	45	520	360	226	48	560	400	266	51	600	440	306	54	640	480	346	57	680	520	386	60
3000	440	280	146	41	440	280	146	42	480	320	186	45	520	360	226	48	560	400	266	51	600	440	306	54	640	480	346	57	680	520	386	60
4000	424	270	159	43	479	325	214	50	534	380	269	57	589	435	324	64	644	490	379	71	699	545	434	78	754	600	489	85	809	655	544	90
5000	512	330	175	69	587	405	250	80	662	480	325	91	737	555	400	102	812	630	475	113	887	705	550	124	962	780	625	135	1037	855	700	146
6000	572	384	210	98	660	472	298	114	748	560	386	130	836	648	474	146	924	736	562	162	1012	824	650	178	1100	912	738	194	1188	1000	826	210

Flange dimensions in accordance with PN40 DIN 2545 at standard pumps. (upon request ANSI 150&300 norm)

PSV Model

Spare Part List of Pump with Mechanical Seal

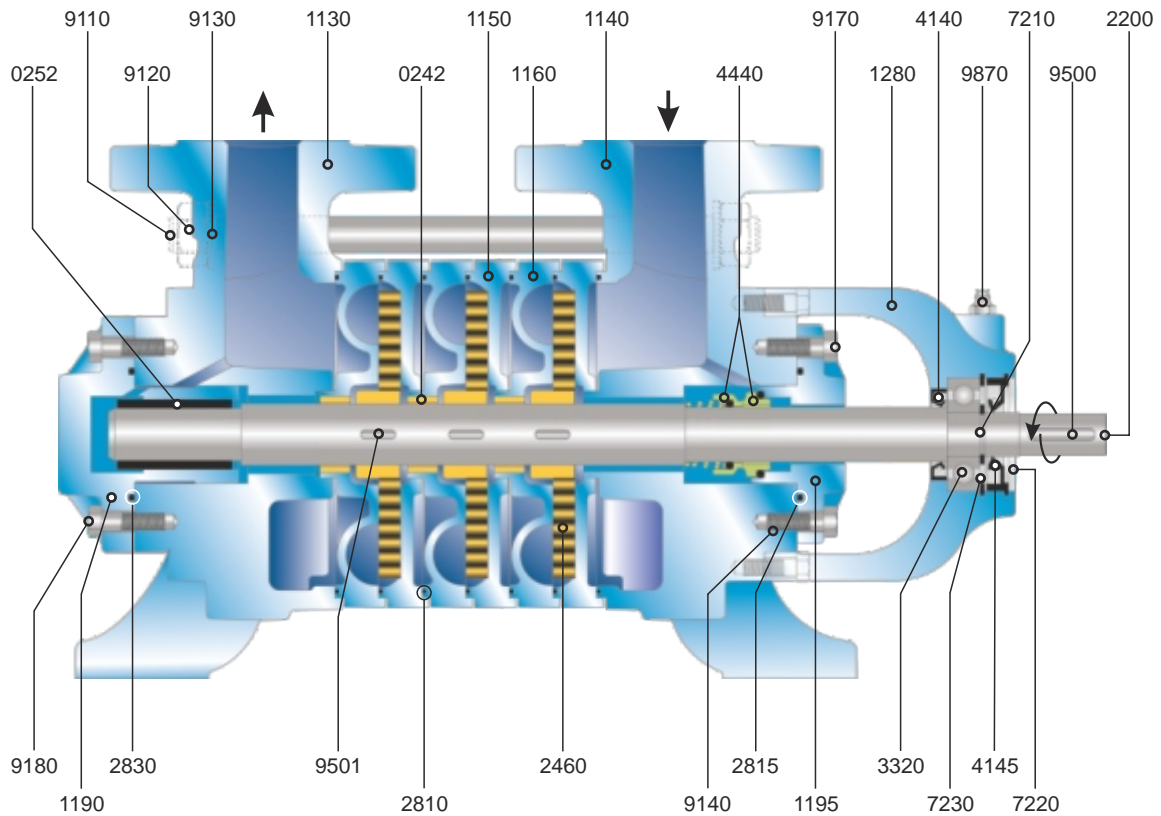

Item	Part List	Item	Part List	Item	Part List
0242	Vane Impeller Bushing	2460	Vane Impeller	7230	Snap Ring for Lip Seal
0252	Discharge Casing Bushing	2810	Stage O-Ring	9110	Tie Bolt
1130	Discharge Casing	2815	Mechanical Seal Casing O-Ring	9120	Tie Bolt Nut
1140	Suction Casing	2830	Bushing Casing O-ring	9130	Tie Bolt Washer
1150	Suction Body	3320	Ball Bearing	9140	Screw for Bearing Casing
1160	Discharge Body	4140	Lip Seal (Inner)	9170	Screw for Mechanical Seal Casing
1190	Discharge Bushing Casing	4145	Lip Seal (Outer)	9180	Screw for Bushing Casing
1195	Mechanical Seal Casing	4440	Mechanical Seal	9500	Flat Key for Coupling
1280	Bearing Casing	7210	Snap Ring for Shaft	9501	Flat Key for Vane Impeller
2200	Shaft	7220	Snap Ring for Bearing	9870	Grease Fitting



- LPG transfer
- LPG Auto Gas Station
- Skid Systems
- Cylinder filling
- Refrigerants (HFC-12, HFC-22, HFC-134A, HFC-410A etc.)
- Low density hydrocarbons (Pentane, Butane, Isobutane, Propan etc.)
- Liquefied gasses (DME, Hexane etc.)
- Oil Filling Plants (Vegetable and animal oils etc.)



Model No: PSC 3008 Underground Tank Application



Model No: PSC 3008 Underground Tank Application



Model No: PSC 2004 Skid System Application for LPG



Model No: PSC 5006 Skid System Application Road Tanker Unloading Pump

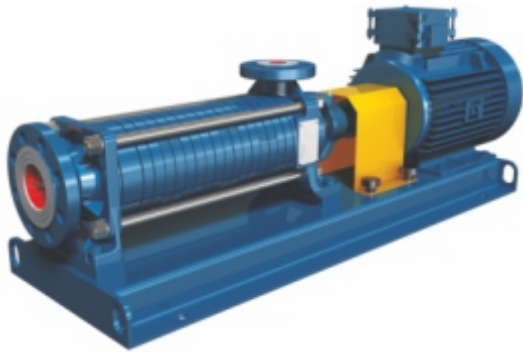

Model No: PSC 5008 / Capacity 20 m³/h 20 Bar



Model No: PSC 6008 / Capacity 35 m³/h 20 Bar



Oil Filling Plants



LPG Storage Tanks Application



LPG Filling Plants Application

Petroland differential by-pass valves are designed to protect pumps and system components from excessive pressure damage.

Petroland by-pass valves can be setted between 0-15 bar.

With only two moving parts, operation is simple and reliable.

By-pass should not be open continuously to protect system against any damage or explosion.

PETROLAND Pumps can be supplied with or without By-Pass Valves.

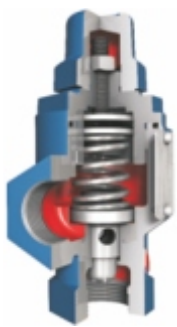

PB Type By-Pass Valve



PBF Type By-Pass Valve

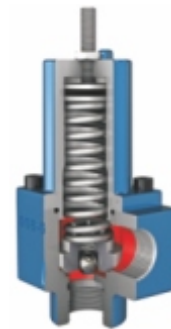

PC Type By-Pass Valve

Technical Specifications and Models of PB Series By-Pass valves			
By-Pass Type	Max. Operating Pressure	By-Pass Inlet-Outlet	Connection Type
PB 25	15 BAR (217.5 psi)	1"	BSP NPT
PB 32		1¼"	
PB 40		1½"	
PB 50		2"	

Technical Specifications and Models of PC Series By-Pass valves			
By-Pass Type	Max. Operating Pressure	By-Pass Inlet-Outlet	Connection Type
PC 25	15 BAR (217.5 psi)	1"	BSP NPT
PC 32		1¼"	
PC 40		1½"	
PC 50		2"	

Technical Specifications and Models of PBF Series By-Pass valves.					
By-Pass Type	Max. Operating Pressure	By-Pass Inlet-Outlet	Connection Type		
PBF 32	15 BAR (217.5 psi)	1¼"	BSP	NPT	Special Flange Application Upon Request
PBF 40		1½"			
PBF 50		2"			
PBF 65		2½"			

By-Pass models and technical specifications.